

# 10/100BASE-T SINGLE PORT TRANSFORMER MODULES

Industrial grade



- Compliant with IEEE 802.3 standards
- 350pH OCL with 8mA DC bias at 100KHz 100mV
- Lead finish: Pure tin
- Moisture Sensitivity Level: 1

## Electrical Specifications @25 °C –Operating temperature : – 40 °C to + 85 °C

Part Number	Insertion Loss (dB MAX)	Return Loss (dB MIN)				Crosstalk (dB MIN)				DM to CM Rejection Ratio (dB MIN)			Dielectric Withstanding Voltage @60s (Vrms MIN)
		0.1-100 MHz	5-30 MHz	50 MHz	60 MHz	80 MHz	1 MHz	30 MHz	60 MHz	100 MHz	30 MHz	60 MHz	
R1022NL	-1.2	-18	-14	-14	-12	-48	-45	-40	-35	-42	-37	-32	1500

Notes: 1. Add suffix "T" to part number for Tape & Reel package (ie: **R1022NLT**).

## Mechanical

R1022NL

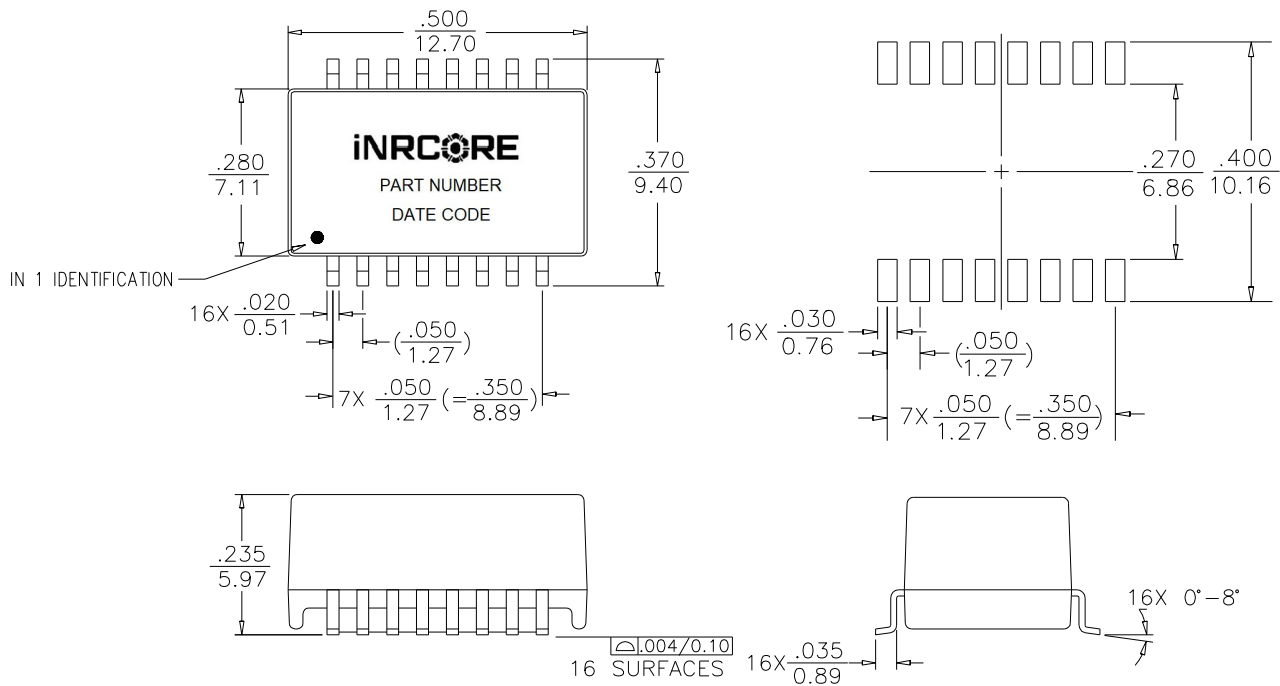

WEIGHT.....APPROX 1.16 GRAMS  
 TAPE & REEL.....600/REEL  
 TUBE.....40/TUBE  
 DIMENSIONS:  $\frac{\text{INCHES}}{\text{MM}}$   
 UNLESS OTHERWISE SPECIFIED, ALL TOLERANCES ARE  $\pm \frac{.010}{0.25}$



# 10/100BASE-T SINGLE PORT TRANSFORMER MODULES

Industrial grade



## Electrical Schematic

R1022NL

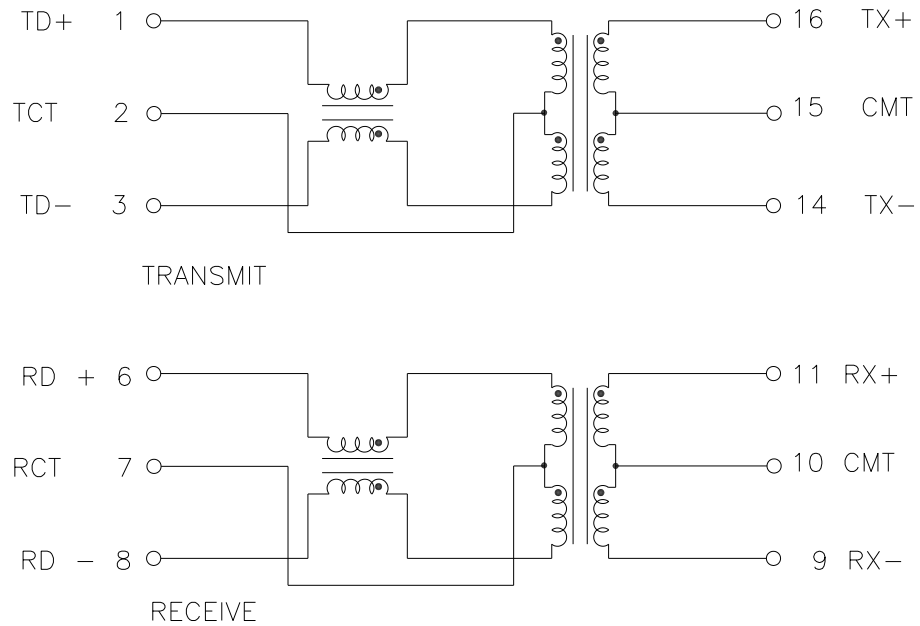

### LEGEND

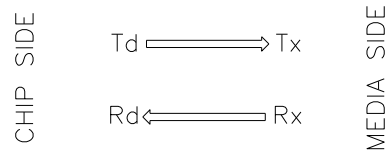

ALL CHANNELS ARE  
IN PHASE BETWEEN  
INPUT TO OUTPUT



# 10/100BASE-T SINGLE PORT TRANSFORMER MODULES

Industrial grade



## Non-Lead Recommended Reflow Profile (Based on J-STD-020D)

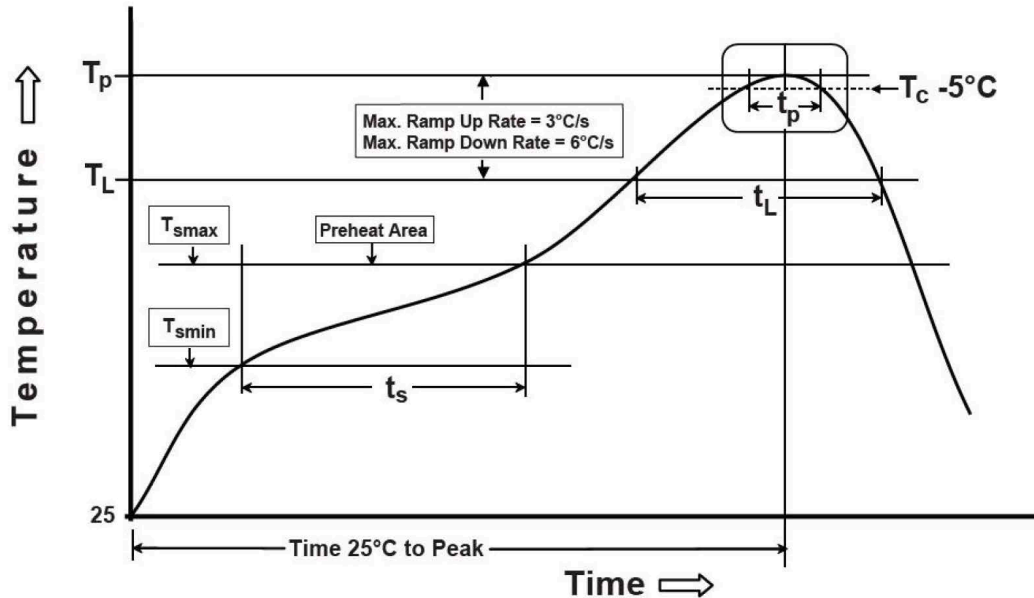

$T_{SMIN}$ (°C)	$T_{SMAX}$ (°C)	$T_L$ (°C)	$T_P$ (°C MAX)	$t_s$ (s)	$t_L$ (s)	$t_p$ (s MAX)	Ramp-up rate ( $T_L$ to $T_P$ )	Ramp-down rate ( $T_P$ to $T_L$ )	Time 25°C to peak temperature (s MAX)
150	200	217	245	60-120	60-150	30	3°C/s MAX	6°C/s MAX	480

Notes:

1. All temperatures measured on the package leads.
2. Maximum times of reflow cycle: 2.

### For More Information

iNRCORE, LLC  
311 Sinclair Road Bristol,  
PA 19007-6812 U.S.A  
Tel: + 1.215.781.6400  
Fax: +1.215.7816430

Dongguan iNRCORE Co. Ltd  
No.7, An Li Road, Changan Town,  
Dongguan City, China  
Tel: +0769 8165 9962

**Global Sales Representatives and Locations:**  
<http://www.inrcore.com>

Performance warranty of products offered on this data sheet is limited to the parameters specified. Data is subject to change without notice. Other brand and product names mentioned herein may be trademarks or registered trademarks of their respective owners. © Copyright, 2020. iNRCORE, LLC. All rights reserved.

