



CASE STUDY

Copperhead™ Series Fibre Channel transceiver line interface module



OVERVIEW

FIBER SPEED DATA AND COMMUNICATIONS OVER 100+ METERS OF COPPER.

Designed to be inter-operable with existing ECL fiber transceiver drivers, Copperhead™ fibre channel copper transceiver line interface modules drive high frequency (fiber speed) signals over copper media. Models TM133 thru TM1062 are designed to deliver fibre channel capabilities to the workstation over shielded twisted pair (STP), twinax, mini coax, and video coaxial cable. Model TM1250 provides communications for short haul Gigabit Ethernet applications, typically over twinax or coaxial cable. Model TM1485 provides communications for SMPTE, also typically over twinax or coax cable. All Copperhead™ fibre channel copper transceiver line interface modules are supplied as surface mount gull wing packages.



Fibre Channel Module

APPLICATIONS

Fibre Channel	HDTV	Gigabit Ethernet
SMPTE	SONET	IEEE 1394B

FEATURES

- High performance, low cost alternative to completely fiber systems
- Enhanced distance and signal clarity with complete inter-operability per ANSI X3T11, FC-PH (FC-0 Rev 9.1)
- Small, discrete passive design incorporates equalizer, transformers, and filters for “short haul” applications; industrial temp -40°C to +85°C (-55°C to +125°C available)
- Compact active models for “long haul” applications; -40°C to +85°C and -55° to +125°
- Low EMI emissions; designed for FCC Class B compliance and use over shielded twisted pair cable with high radiated electromagnetic susceptibility - 10 V/m
- Low transmit/receive jitter
- Small footprint for surface mounting
- Low power dissipation; 450 mW typical
- ECL logic interface - directly compatible with proposed standards

BEFORE

Unequalized

Actual oscilloscope tracing of 1.0625 Gb/s unequalized input to receiver pins 13 and 14 after transmission over 30 meters of twinax cable.

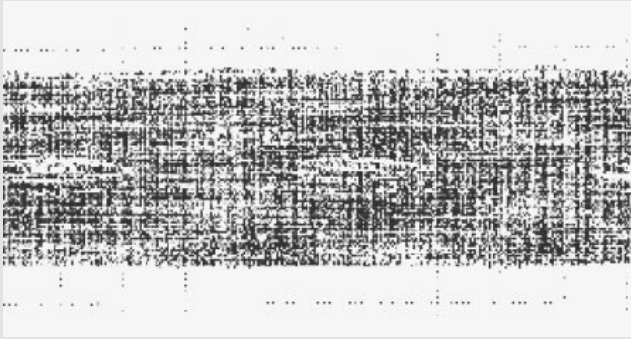

Figure 1

AFTER

Equalized for Fibre Channel

Tracing of the same signal after equalization. Receiver output measured at pins 2 and 3.

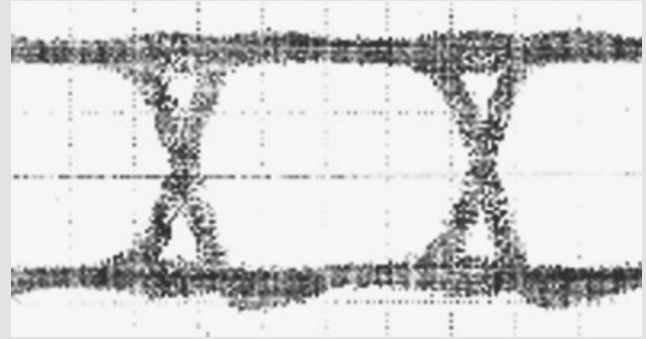

Figure 2

TECHNICAL DESCRIPTION

Copperhead™ fibre channel transceiver line interface modules (LIM) take differential ECL level NRZ data signal from the available fibre channel (or Gigabit Ethernet) silicon. The signal is then converted to drive level, pre-conditioned with an output filter, and transmitted over the cable through an interfacing wideband pulse transformer.

The transformer converts the signal to current and voltage levels, with exceptionally low transmit jitter, suitable for transmission on STP, twinax or coaxial cable. The transceiver matches the impedance of both the ECL circuit and the cable plant, providing a resultant output signal with minimum jitter and return loss.

The receiver portion of the transceiver LIM takes the signal from the media cable and equalizes it by using a unique wideband pulse transformer and circuitry. This initiates the conversion process of reducing the composite signal to ECL level NRZ for the next level fibre channel silicon.

BENEFITS OF TRANSFORMER COUPLING

The pulse transformers used in Copperhead™ transceiver LIMs provide high isolation and optimum damping of transients. They also eliminate DC components in the signal and provide common mode signal rejection. The transformer is also used to match the load to the source and provide maximum power transfer, and also to prevent reflections from transmission line effects.

PRODUCT QUALIFICATION TEST OUTLINE

I. Subgroup I (all devices - 40 pieces)

ELECTRICAL TESTS AT 25°

- Receiver (Rx) tests
 - Jitter (total peak-to-peak)
- Transmit (TX) tests
 - CMI Mask Test (rise time, fall time, and amplitude)
 - Jitter (total peak-to-peak)
- Total power supply current

II. Subgroup II (4 pieces)

EXTERNAL VISUAL INSPECTION

- Resistance to solvents per MIL-STD-202, Method 215H
 - 1 part isopropyl alcohol, 3 parts mineral spirits
 - Trichloroethane
 - Terpene defluxer with a minimum of 90% d-limonene and 10% surfactant
 - 42 parts water, 1 part propylene glycol monomethyl ether, 1 part monoethanolamine
- Terminal strength per MIL-STD-883, Method 2004.5
 - Lead tension

III. Subgroup III (4 pieces)

SOLDERABILITY

- Per MIL-STD-202, Method 208, with a 4-hour steam age

IV. Subgroup IV (6 pieces)

RESISTANCE TO SOLDERING HEAT

- Hand solder (2 pieces), solder dip temperature of 430 ±5° C for 3 seconds maximum
- Vapor phase reflow (4 pieces) for a period of 60 seconds at a temperature of 215 +5/-0° C

V. Subgroup V (6 pieces)

THERMAL SHOCK

- Per MIL-STD-202, Method 107, Condition A-1, except temperature range shall be -20° C to +125° C, 25 cycles

VIBRATION

- Per MIL-STD-202, Method 204D, Condition D, 20G peak acceleration, 10 Hz to 2 KHz and return to 10 Hz traversed in 6 minutes

SHOCK

- Per MIL-STD-202, Method 213B, Condition J, 30G, 11msec shock, 3 shocks in each direction along mutually perpendicular axes

VI. Subgroup VI (6 pieces)

LIFE TEST

- Per MIL-STD-202, Method 108, 1000 hours at a temperature of 75° C

VII. Subgroup VII (8 pieces)

HUMIDITY TEST

- Humidity test @ 40° C, and 90% humidity (4 pieces)

VIII. Subgroup VIII (6 pieces)

ELECTROSTATIC DISCHARGE, ESD CLASSIFICATION

- The ESD classification to be derived from ESD testing per IEC801-2, EN50082-1, Criteria B

NOTE: There shall be 0 (zero) rejects allowable for each of the subgroups.

EMC IMMUNITY AND RADIATED EMISSIONS TESTS

- Radiated Emissions, FCC Class B, 6 dB margin
- IEC 1000-4-3 Radiated Immunity Performance Criteria A, Level 3 (10V/m)

Criteria A

The system shall continue to operate normally. The EUT shall be deemed to have passed the immunity tests if no bit errors occur when receiving data over the cable. Changes of state, reset condition, unrecoverable jab condition, blocked network, or loss of packets is unacceptable.

- IEC 1000-4-2 ESD Test Method Performance Criteria B, Level 2
- IEC 1000-4-4 EFT Test Method Performance Criteria B, Level 3 (at I/O port)

Criteria B

The system shall operate normally with no data errors through the loop after the test. During the test, data errors, aborted frames and collisions are acceptable. No change of operating state such as system reset or unrecoverable condition is permitted during or after the test.

TABLE 1 ABSOLUTE MAXIMUM RATINGS

PARAMETER	SYM	MIN	MAX	UNIT
Storage temperature	T _s	-55	+150	°C
Operating temperature ambient — Active ¹	T _A	-40	+85	°C
Operating temperature ambient — Passive	T _A	-55	+125	°C
Power supply voltage (MECL, PECL or LVPECL)	V _{cc}	-6.0	6.0	V
Power supply current ²	I _c	—	95	mA
Power dissipation (total)	P _D	—	500	mW
Output current	I _o	—	100	mA
Data input voltage	V _I	0	V _{cc} + 0.5	V
Differential input voltage	V _D	—	2.40	V
Component body temperature/time	—	—	220/60	°C/s
Thermal	(thet a) _{jc}	—	54	°C/w

Note 1: Exception: for TM1062DSA1, -55° to +125°C

Note 2: Excluding external pull-down resistors

IMPORTANT

This is a hybrid device and is rated for 220°C max for 60 seconds. Contact factory for recommended solder reflow profile.

TABLE 2 SYSTEM JITTER BUDGET

Copperhead™ fibre channel copper transceivers require less than 50% (worst case) of system jitter budget

JITTER PARAMETER	TOTAL JITTER				Unit
	133 Mb	266 Mb	531 Mb	1.062 Gb	
Data rate	133 Mb	266 Mb	531 Mb	1.062 Gb	Unit
Transmit in (PHY)	1.204	0.602	0.377	0.188	ns
Transmit out (PHY+ Transmitter)	1.356	0.678	0.414	0.207	ns
Receive out (PHY+ Transmitter+ Cable+ Receiver)	6.0	2.64	1.32	0.658	ns

Note: These numbers are currently under evaluation by a special Jitter Study Group in ANSI X3T11 and IEEE 802.3z.

TABLE 3 TRANSMITTER ELECTRICAL CHARACTERISTICS

PARAMETER	SYM	MIN	TYPICAL	MAX	UNIT
Input data voltage — Low	V _{IL}	V _{CC} -1.95	V _{CC} -1.75	V _{CC} -1.45	V
Input data voltage — High	V _{IH}	V _{CC} -1.23	V _{CC} -0.88	V _{CC} -0.72	V
Input current — Low	V _{IL}	-150	—	—	uA
Input current — High	V _{IH}	—	—	150	uA
Data rate (NRZ Encoding)	DR	133	—	1485	Mb/s
Differential signal level ¹ TMXXXXXSA ¹	V _{OT}	1100	—	2000	mV
(peak-peak) TMXXXXXSA ¹		600	—	1600	mV
Output rise and fall time ¹ for TM1062 (20-80%)	T _R / T _F	—	—	300	ps
Return loss (0.1 to 0.5 of baud rate)	S ₁₁	-12	—	—	dB
Total peak-peak transmit jitter (D_J + R_J)					
	T _{PK-PK}				
12- TP-EL-S	133 Mb	—	500	750	ps
25- TP-EL-S	266 Mb	—	250	376	ps
50- TP-EL-S	531 Mb	—	125	188	ps
100-TP-EL-S	1062 Mb	—	62	94	ps
	1250 Mb				
	1485 Mb				

Note 1: Differential signal level (VOT), rise time (TR) and overshoot (OS) shall be measured at the transmitter output with 150 ohm differential termination as load. The data pattern for this test shall be a square wave of 0.1 bit rate.

V_{CC} = 3.14V to 5.25V

TABLE 4 RECEIVER ELECTRICAL CHARACTERISTICS

PARAMETER	SYM	MIN	TYPICAL	MAX	UNIT
Output data voltage — Low	V _{OL}	V _{CC} -1.95	V _{CC} -1.77	V _{CC} -1.56	V
Output data voltage — High	V _{OH}	V _{CC} -1.15	V _{CC} -0.96	V _{CC} -0.76	V
Data rate (NRZ Encoding)	DR	133	—	1485	Mb/s
Input sensitivity (D21.5 idle pattern)	—	150	—	—	mV
Input differential voltage	V _{DIFF}	—	—	2.40	V
Return loss (0.1 to 0.5 bit rate) STP	S ₁₁	-15	-17	—	dB
Total peak-peak receive jitter					
	T _{PK-PK}				
	133 Mb	—	0.350	1.500	ns
	266 Mb	—	0.350	0.900	ns
	531 Mb	—	0.240	0.650	ns
	1062 Mb	—	0.120	0.400	ns
	1250 Mb				
	1485 Mb				

APPLICATION GUIDE

The transceiver type (passive/short haul or active/long haul) is based on the cable insertion loss (attenuation) for the length of cable in question. Pulse Components Division recommends the product type/cable length combinations listed below. Specific models recommended as examples are based on installation/use within 1 Gbaud /150 ohm systems.

CABLE LENGTH	PART TYPE	EXAMPLE MODEL	DESCRIPTION
10 meters	Equalization rarely required.		For use in applications < 10 meters requiring isolation and common mode signal rejection, see T-1062 data sheet for dual (TX & RX) pulse transformer products.
Short Haul 10-30 meters	Copperhead™ passive transceiver module	TM1062HSCT without active logic chip and buffering	For use in applications presenting an input voltage of no less than 400 mV (from cable) to transceiver RX. An insertion loss (S21) calculation with respect to cable length should be made in order to determine compliance. If the voltage is less than 400 mV, use “long haul” device (below).
Long Haul > 30 meters	Copperhead™ transceiver module with active logic chip and buffering for receive side only	TM1062DSA with active receive amplifier	For use in long haul applications where losses accumulate and diminish (receive) signal strength. This device requires a minimum input signal of only 100 mV (from cable) to transceiver RX.
Long Haul > 30 meters, enhanced transmit	Copperhead™ transceiver module with active logic chip and buffering for both receive and transmit sides	TM1062DSA1 with active transmit driver and receive amplifier	For use in long haul applications requiring buffered transmit signal. The active transmitter acts as a buffer. It reconditions the signal to the appropriate drive level. Transmitter output signal level is 1100 mV minimum.

BLOCK DIAGRAM FOR “LONG HAUL” APPLICATION

Shown is an application of the Model TM1062DSA with “active receive” amplifier for a “long haul” application presenting an input voltage of less than 400 mV (from cable) to transceiver RX.

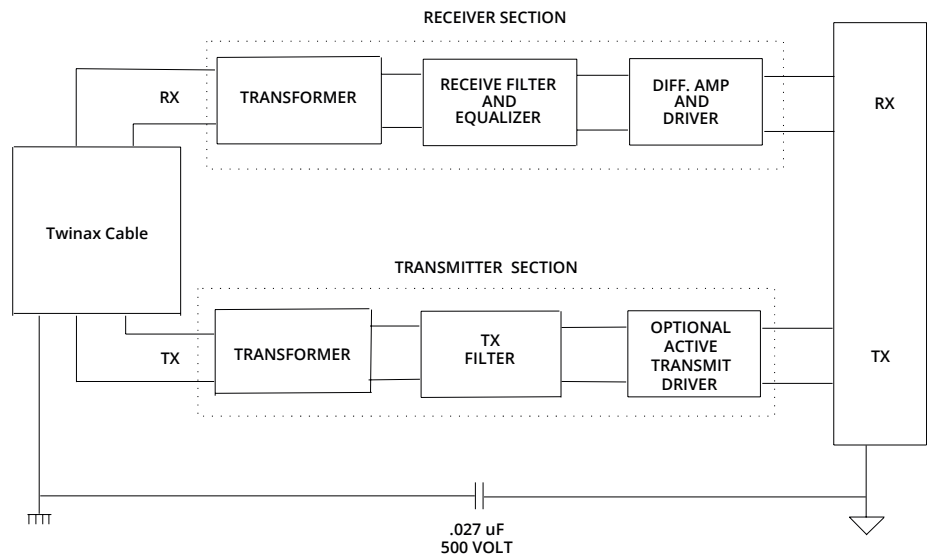

MODULE PINOUTS

PIN NUMBERS

1, 28	The positive supply for the line interface module. Connect to +5.0V for PECL applications, and to Gnd for ECL applications.
2, 3	DO, DO: Differential ECL data outputs. These outputs can drive 50 ohm loads connected to VCC -2.0V. Recommend 330 ohms to Gnd.
7, 8	Gnd (VEE): The negative supply for the line interface module. Connect to Gnd for raised ECL (PECL) applications, and to -5.2V for standard ECL applications.
13, 14	RX-, RX+ : Transformer coupled differential inputs to receiver section. For coax applications, RX- should be connected to shield of cable/earth Gnd; RX+ should be connected to the center conductor. Earth Gnd should be AC coupled to DC signal Gnd using a 0.027 μ F capacitor, \sim 500V.
15, 16	TX+, TX- : Transformer coupled differential outputs to cable. For coax applications, TX- should be connected to shield of cable/earth Gnd; TX+ should be connected to the center conductor. Earth Gnd should be AC coupled to DC signal Gnd using a 0.027 μ F capacitor, 500V.
21, 22	Gnd (VEE): The negative supply for the line interface module. Connect to Gnd for raised ECL (PECL) applications, and to -5.2V for standard ECL applications.
23	VBB : Is an output pin, which is used for biasing up a threshold reference level, i.e. PECL (3.67V). This pin can only source 1 mA maximum.
24, 25	DI, DI : Differential ECL compatible data inputs to the transmitter side of the module.
4, 5, 6, 9, 10, 11, 12, 17, 18, 19, 20, 26, 27	These pins are "no connect;" do not apply Gnd, VCC, or signal lines to these pins.

BOARD LAYOUT CONSIDERATIONS

- 0.1 μ F capacitors should be ceramic and placed as close to the VCC pins (1 & 28) of the transceiver as possible.
- Differential lines should be of equal length.
- Data out and signal detect output lines should be as short as possible and isolated from noisy sources.
- Controlled impedance traces from pins 14 (RX+) and 15 (TX+) of the transceiver to the BNCs or DB9 connector must be used in order to control return loss.
- A DC signal ground plane should occupy the complete area directly beneath the transceiver LIM from pins 1-2 and 17-28.
- The earth ground plane should occupy the complete area directly beneath pins 13-14 and 15-16.
- There should be a separation of 0.050" between earth and DC ground.
- The earth ground should be AC coupled to DC ground with a 0.027 μ F capacitor on both sides of the transceiver (TX side and RX side).

BLOCK DIAGRAM FOR "SHORT HAUL" APPLICATION

Shown is an application of the Model TM1062HSCT passive transceiver LIM, used in a "short haul" application presenting an input voltage of no less than 400 mV (from cable) to transceiver RX.

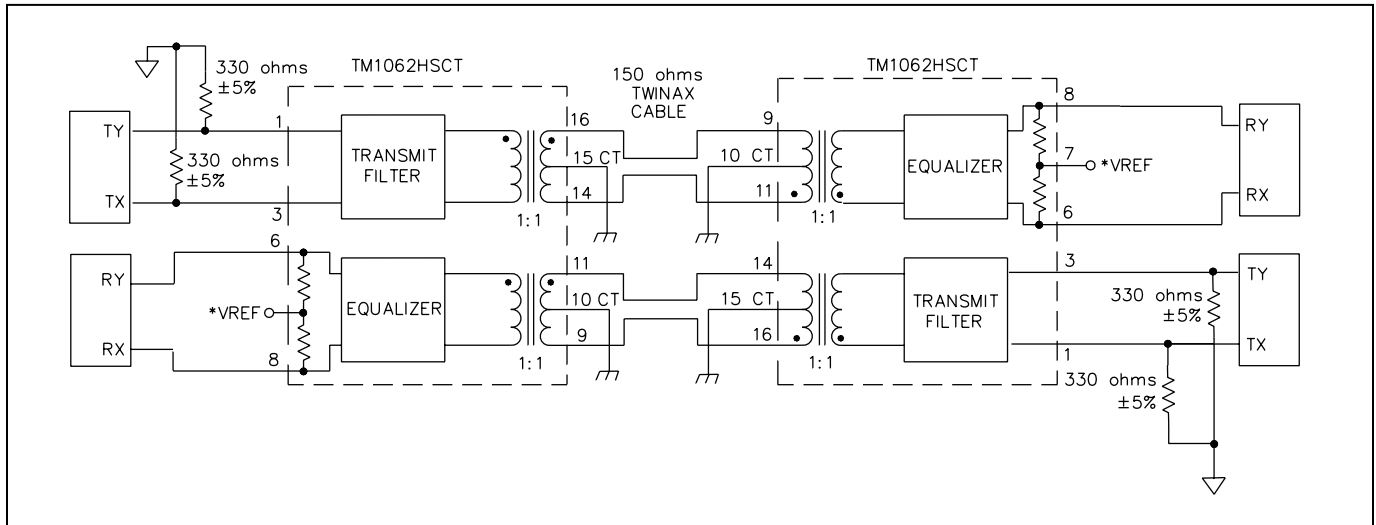

"H" PACKAGE PASSIVE TRANSCEIVER FOR "SHORT HAUL" APPLICATION

Dimensions

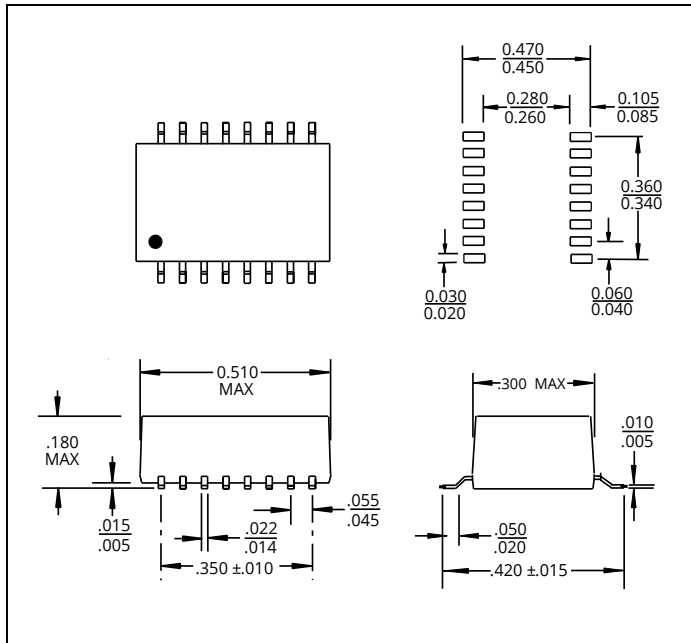

Pin Assignment

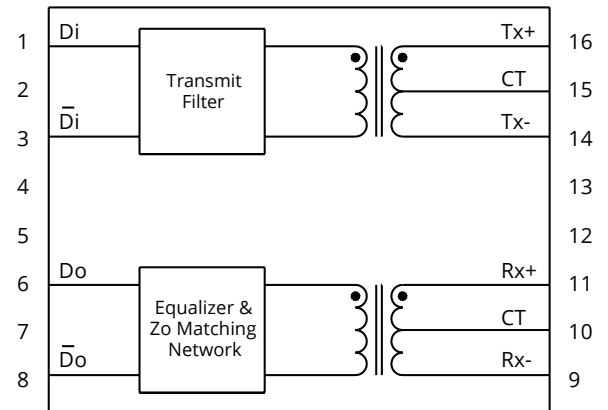

DIMENSIONS AND TEST CIRCUIT "D" PACKAGE (DIP)

Test circuit shown is for coax single-ended application

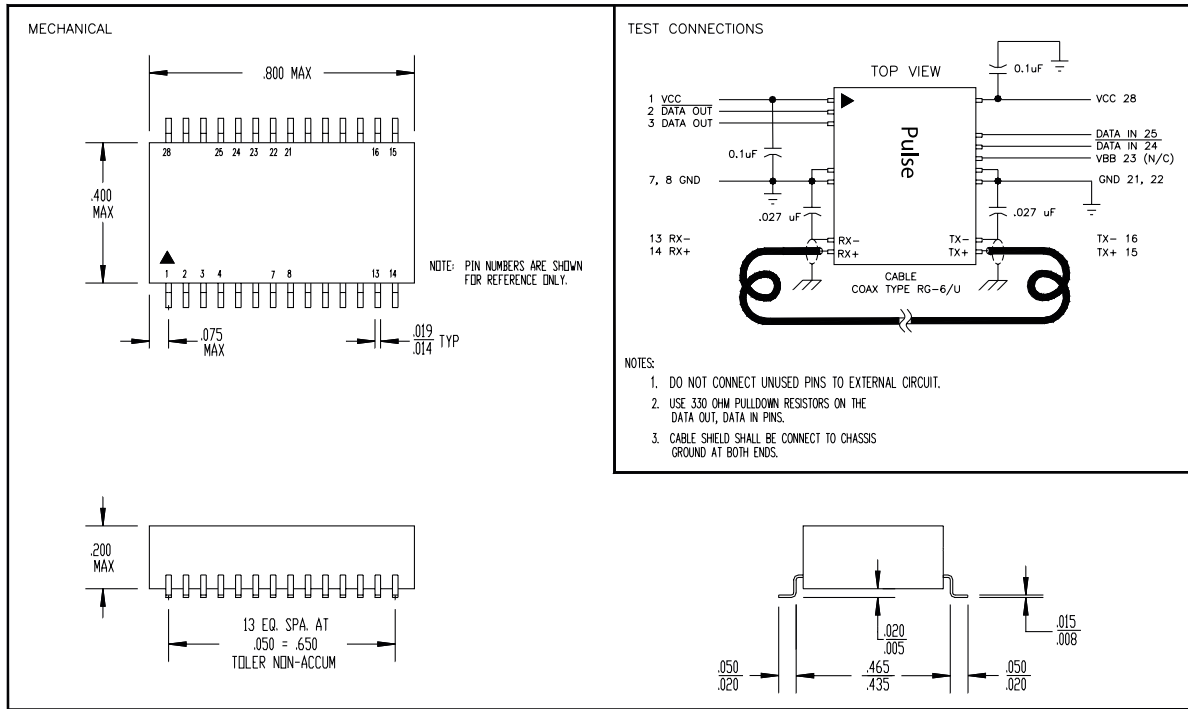

DIMENSIONS AND TEST CIRCUIT "F" PACKAGE (FLAT PACK)

Test circuit shown is for twinax/STP differential application

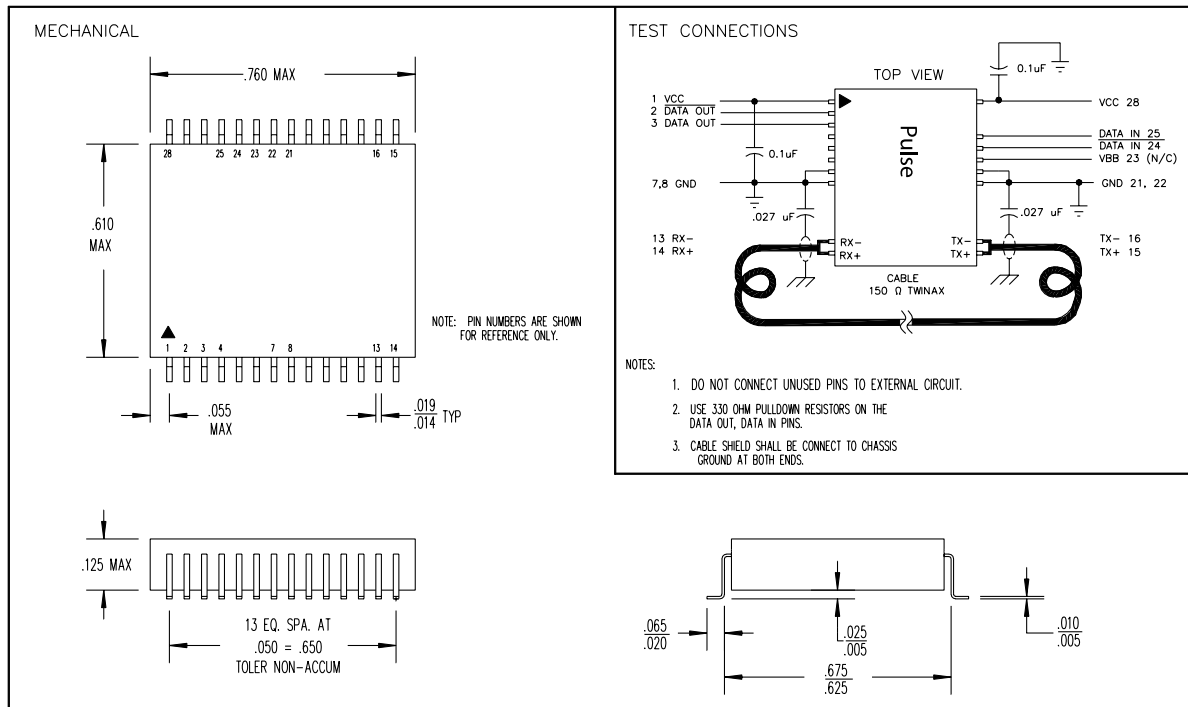

Note: Test circuits for both package types are interchangeable.

ORDERING INFORMATION

Example

TM 531 D S A 1 (XX)

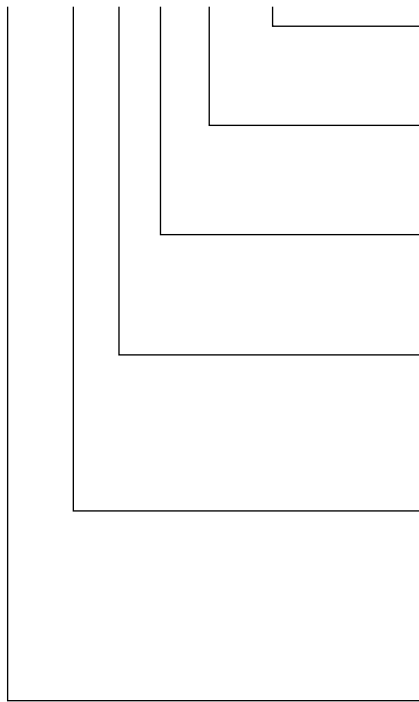

(XX) Custom product designator

blank No transmit driver

1 1100 mV output transmit driver and military temperature range

2 1100 mV output transmit driver and industrial temperature range

5 Active cable equalizer circuit

A 5.00 Volt

B 3.30 Volt

S Impedance matched for STP and twinax (150 ohm)

U Impedance matched for unshielded twisted pair (100 ohm)

V Impedance matched for video and mini-coax (75 ohm)

C Impedance matched for coax (50 ohm)

D Gull wing DIP 28-pin package: 0.800"L x 0.400"W x 0.200"H

F Gull wing flat pack 28-pin package: 0.760"L x 0.610"W x 0.125"H

H Gull wing half DIP 16-pin package: 0.300"L x 0.500"W x 0.250"H
(16-pin package is only available on passive units.)

133 132.8125 Mbaud version 1/8 speed Fibre Channel/ATM

266 265.625 Mbaud version 1/4 Speed Fibre Channel

531 531.25 Mbaud version 1/2 Speed Fibre Channel

1062 1.0625 Gbaud version Full Speed Fibre Channel

1250 1.250 Gbaud version, Gigabit Ethernet (both short haul and long haul)

1485 1.485 Gbaud version, SMPTE

RELATED PRODUCTS

SERIES	FEATURES
TM311DVA	311.04 Mb version SONET STM1 (also SONET E4 278.528 Mb) CMI
TM311TRFVA	311.04 Mb version SONET STM1 (also SONET E4 278.528 Mb) CMI with G.775 LOS
TM1062 Series	1.0625 Gbaud version; short haul and long haul models
T-330SCT	330 Mbaud "HOT LINK" / 265.625 Mbaud version 1/4 speed Fibre Channel Transformer
T-1062SCT	1.0625 Gbaud version full speed Fibre Channel Transformer
TC155/311	Bi-directional fiber (NRZ) to copper (CMI) connection-ready converter for E4/STM-1/OC3

FIBRE CHANNEL AND CMI LINE INTERFACE PRODUCTS

for today's fastest LAN and WAN applications.

Bi-directional fiber (NRZ) to copper (CMI) converter.



Built for E4/STM-1/OC3 applications to conduct bi-directional cross media data, voice, and video communications at fiber speed data rates. These modules provide all connections and signal conditioning for NRZ/CMI network junctions. Besides the signal connections, all that is required is 12Vdc power. Very low transmit/receive jitter. Loss of signal detection. Maximum operating distance exceeds 200 meters on 75 ohm RG-6/u and RG-11/u coaxial cable. Compact and easy to install.

SONET/SDH (CMI) serial line interface modules (LIM).



Compact, one-package line interface units for interfacing to the most widely used SONET/SDH chip sets for E4/STM-1 applications. CMI transceiver line interface modules offer a convenient, one package, high performance solution for the complex chip interfacing requirements of CMI applications. The compact packages include transformer coupling for both TX and RX functions, an equalizer, a differential amplifier, and buffering for ECL level input and output. Designed to be inter-operable with existing ECL fiber transceiver drivers, the transceivers meet SONET/ ITU-T requirements for coded mark inversion (CMI) data transmission over copper. The transceivers function equally well in both 311.04 Mb/s SONET STM-1 CMI and 278.528 Mb/s SONET E4 CMI applications, delivering fiber speed data transmission and reception over more than 200 meters of 75 ohm RG-6/u or RG-11/u coaxial cable.

High Frequency Balun Adapter for 150-ohm Fibre Channel, 100-ohm Gigabit Ethernet, and 78-ohm high-speed 1553.



These wide-band baluns provide the impedance matching and isolation necessary to interface a 50-ohm grounded test instrument with a differential circuit under test. They convert a balanced differential-mode signal to a grounded unbalanced 50-ohm signal with less than 2 dB insertion loss and greater than 15 dB return loss from 1.0 MHz to 1.2 GHz. This permits accurate and repeatable measurements of signal quality, such as insertion loss, transmission loss, and return loss. Each balun has a terminator network and correlation data for periodic calibration verification. Terminal pins to connect the network under test to the balun are included.

Fibre Channel (SAN) dual transformers.



Designed specifically for point-to-point coupling to 150 ohm twinax cable. The isolation transformers protect the station from static charges that may develop on the cable and prevents ground loop currents from being transferred between stations. The devices have also been designed to provide common mode rejection within the transmission band and thus reduce EMI. The wide bandwidth of these devices minimizes data dependent jitter by providing fast signal rise times. Low-end bandwidth also minimizes base-line wander, another contributor to jitter. The dual package allows connection of both the transmit and receive channel.

WARRANTY

Pulse Specialty Components warrants for a period of 90 days from the date of shipment, that under normal use and service, its products will be free from defects in workmanship and material. Pulse Specialty Components' sole responsibility under this warranty is, at its option, to repair or replace, without charge, any defective product or part, or to credit buyer for the purchase price of such defective product, provided:

1. Buyer promptly notifies Pulse Specialty Components in writing within the warranty period, and
2. The defective product or part is returned to Pulse Specialty Components with transportation charges prepaid by Buyer, and
3. Pulse Specialty Components examination of such product shall disclose to its satisfaction that said defect exists and has not been caused by misuse, neglect, improper installation, repair or alteration, or accident.

Except for the above warranty and the implied warranty of title, pulse specialty components makes no other warranties, express or implied, including any implied warranty of merchantability or fitness for any particular purpose. No liability is assumed for expendable items such as lamps and fuses. Pulse specialty components will not be liable for incidental or consequential damages under any circumstances.

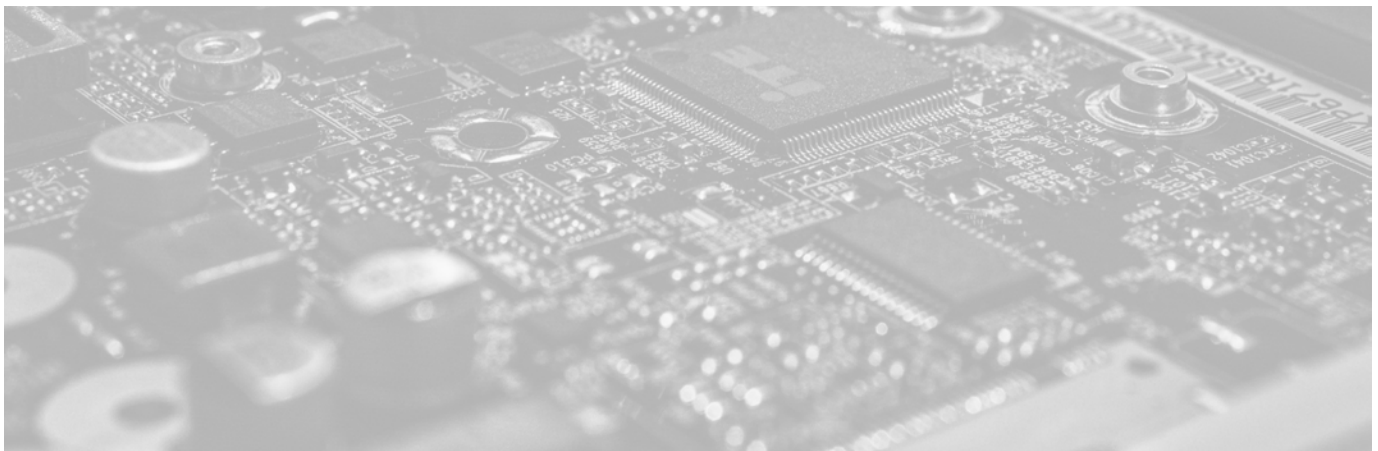

CONTACT US

Your single source for high reliability
custom magnetic solutions

