

- ⊗ Ruggedized header with POGO pins for secure board mounting
- ⊗ Current Rating: up to 23.8ADC
- ⊗ Frequency Range: up to 1MHz
- ⊗ Operating Temperature: -55°C to +130°C
- ⊗ Lead Finish: Sn63/Pb37
- ⊗ Moisture Sensitivity Level: 3

### Electrical Specifications @ 25°C

Part Number	Inductance @ Irated (μH)	Irated (A)	DCR (mΩ)		Inductance @ 0 ADC (μH)	ET REF <sup>2</sup> (Volt-μsec)	Flux Density Factor (K1)	Core Loss Factor (K2)	Temp. Rise Factor (K3)	Connection
			TYP	MAX						
POGO 40										
PL8400	43.6	1.1	247.2	309	77	7.83	0.295	1.87E-10	114.23	Single
POGO 50										
PL8401	21.9	2.70	72.4	90.5	39.5	6.90	0.297	3.35E-10	85.71	Single
PL8402	4.025	6.40	18.4	23.0	6.575	3.135	0.638	4.52E-10	67.89	Single
PL8403	0.53	23.80	1.0	3.0	0.88	1.00	2.020	3.35E-10	85.71	Parallel
PL8404	1.10	21.00	1.7	2.5	2.10	1.75	1.116	4.52E-10	67.89	Parallel
POGO 60										
PL8405	2.1	22.4	2.5	3.4	4.0	3.25	0.559	9.58E-10	44.56	Parallel

### NOTES:

1. Add suffix "NL" for RoHS compliant version; i.e. PL8304 becomes **PL8400NL**. NL parts have 100% SN Lead Finish (MSL:4)
2. For Tape & Reel packaging, add "T" suffix at the end of the part number: i.e. **PL8400T**.
3. Reference values are for inductors with a 55°C temperature rise. The core loss is 10% of the copper loss at the ET listed and 500kHz.
4. Core does not saturate abruptly. The ET and DC current are limited by the desired inductance and temperature rise.

Estimated Temperature Rise:

$$\text{Trise} = K3 \& \text{ (Coreloss(W) + Copperloss(W))}^{0.833}(\text{C})$$

$$\text{CopperLoss} = \text{Irms}^2 \& \text{ DCR\_Typical(mW)} / 1000$$

$$\text{CoreLoss} = K2 \& \text{ (Freq\_kHz)}^{1.26} \& \text{ (DB)}^{2.11}$$

$$\Delta B = K1 \& \text{ Volt-}\mu\text{sec} \& 100$$

5. In high volt-time applications, additional heating in the component can occur due to core losses in the inductor which may necessitate derating the current in order to limit the temperature rise of the component. In order to determine the approximate total losses (or temperature rise) for a given application, both copper and core losses should be taken into account.

### Mechanicals

### Electrical Schematics

PL84XX

Dimensions: inch [mm]  
Tolerance (unless otherwise specified): ±0.010 [0.25]

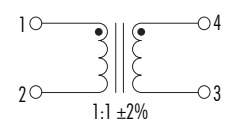
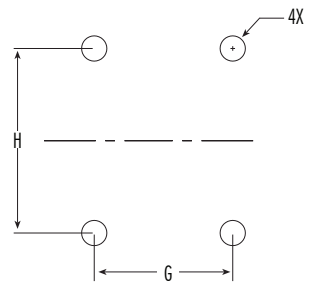
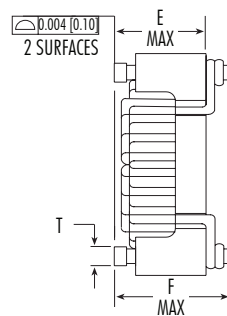
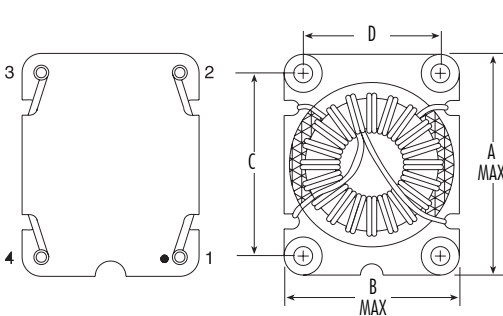

Package	A	B	C	D	E	F	G	H	J	T	Weight MAX (g)	Tube	Reel
POGO 40	0.725 [18.42]	0.575 [14.61]	0.600 [15.24]	0.450 [11.43]	0.310 [7.87]	0.380 [9.65]	0.450 [11.43]	0.600 [15.24]	0.082 [2.08]	0.062 [1.57]	3.5	30	300
POGO 50	0.910 [23.11]	0.700 [17.78]	0.730 [18.54]	0.520 [13.21]	0.400 [10.16]	0.510 [12.95]	0.520 [13.21]	0.730 [18.54]	0.145 [3.68]	0.125 [3.18]	8.2	35	200
POGO 60	1.280 [32.51]	1.070 [27.18]	1.100 [27.94]	0.890 [22.61]	0.400 [10.16]	0.510 [12.95]	0.890 [22.61]	1.100 [27.94]	0.145 [3.68]	0.125 [3.18]	14.2	15	100



### Tin/Lead Recommended Reflow Profile (Based on J-STD-020D)

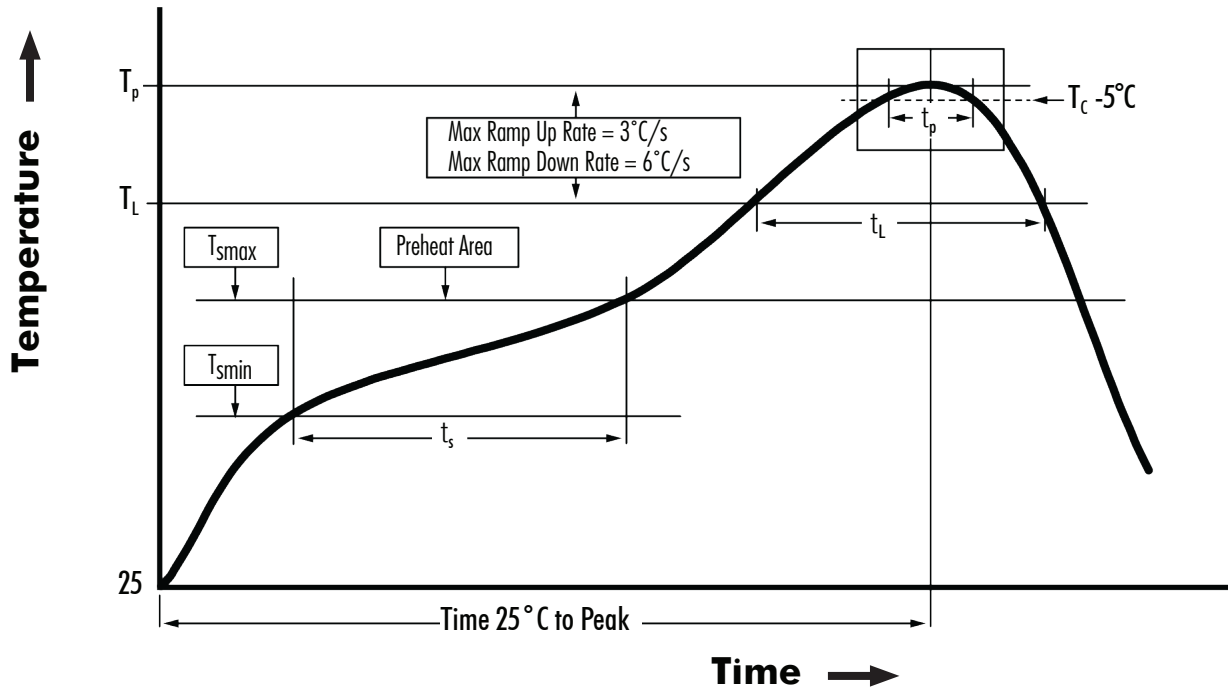

$T_{SMIN}$ (°C)	$T_{SMAX}$ (°C)	$T_L$ (°C)	$T_P$ (°C MAX)	$t_s$ (s)	$t_L$ (s)	$t_p$ (s MAX)	Ramp-up rate ( $T_L$ to $T_p$ )	Ramp-down rate ( $T_p$ to $T_L$ )	Time 25°C to peak temperature (s MAX)
100	150	183	235	60 - 120	60 - 150	20	3°C/s MAX	6°C/s MAX	360

**NOTES:**

1. All temperatures measured on the package leads.
2. Maximum number of reflow cycles not to exceed 2.

